

# MAXHUB EST11 Product Specification

## Appearance

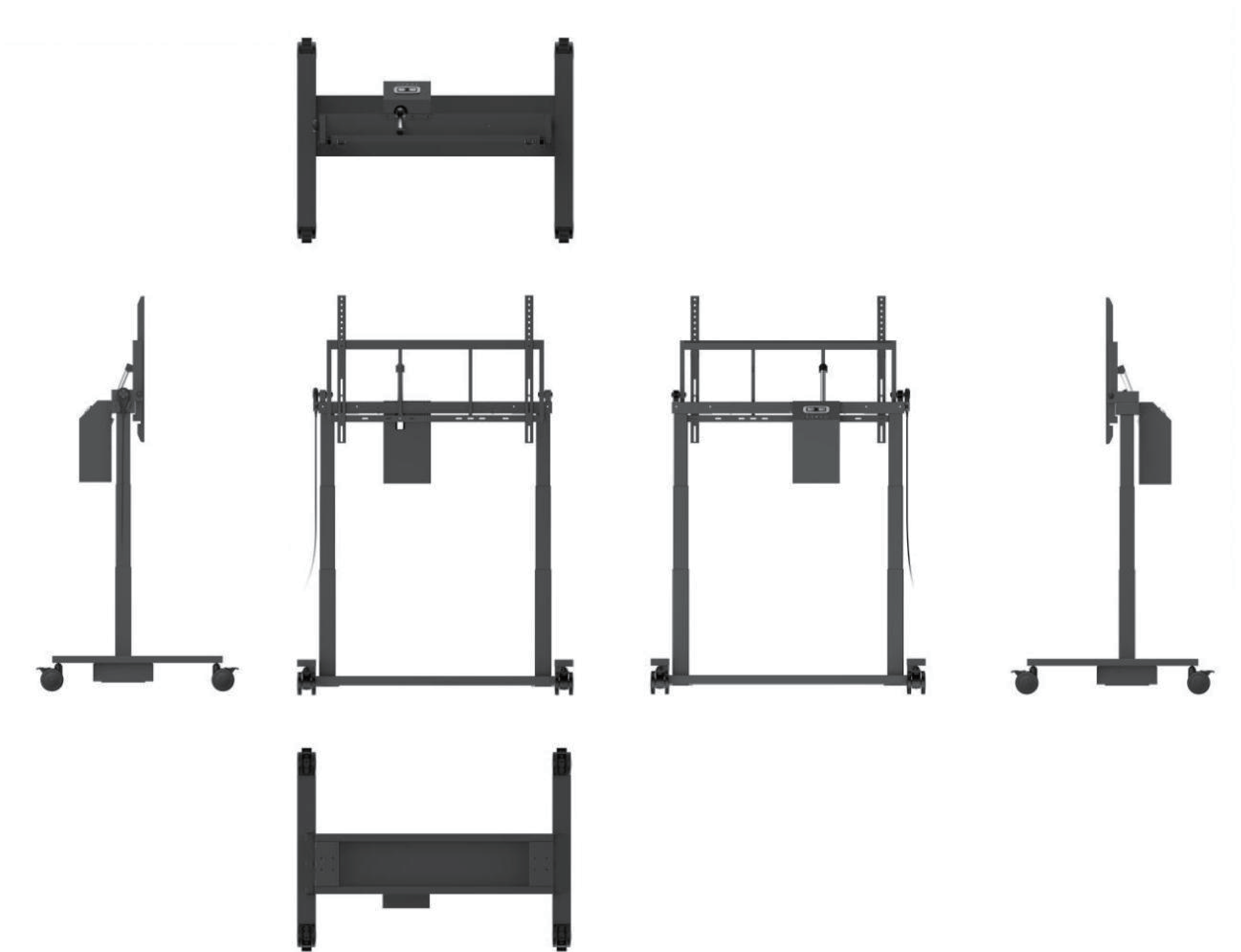

# EST11

## Dimensions

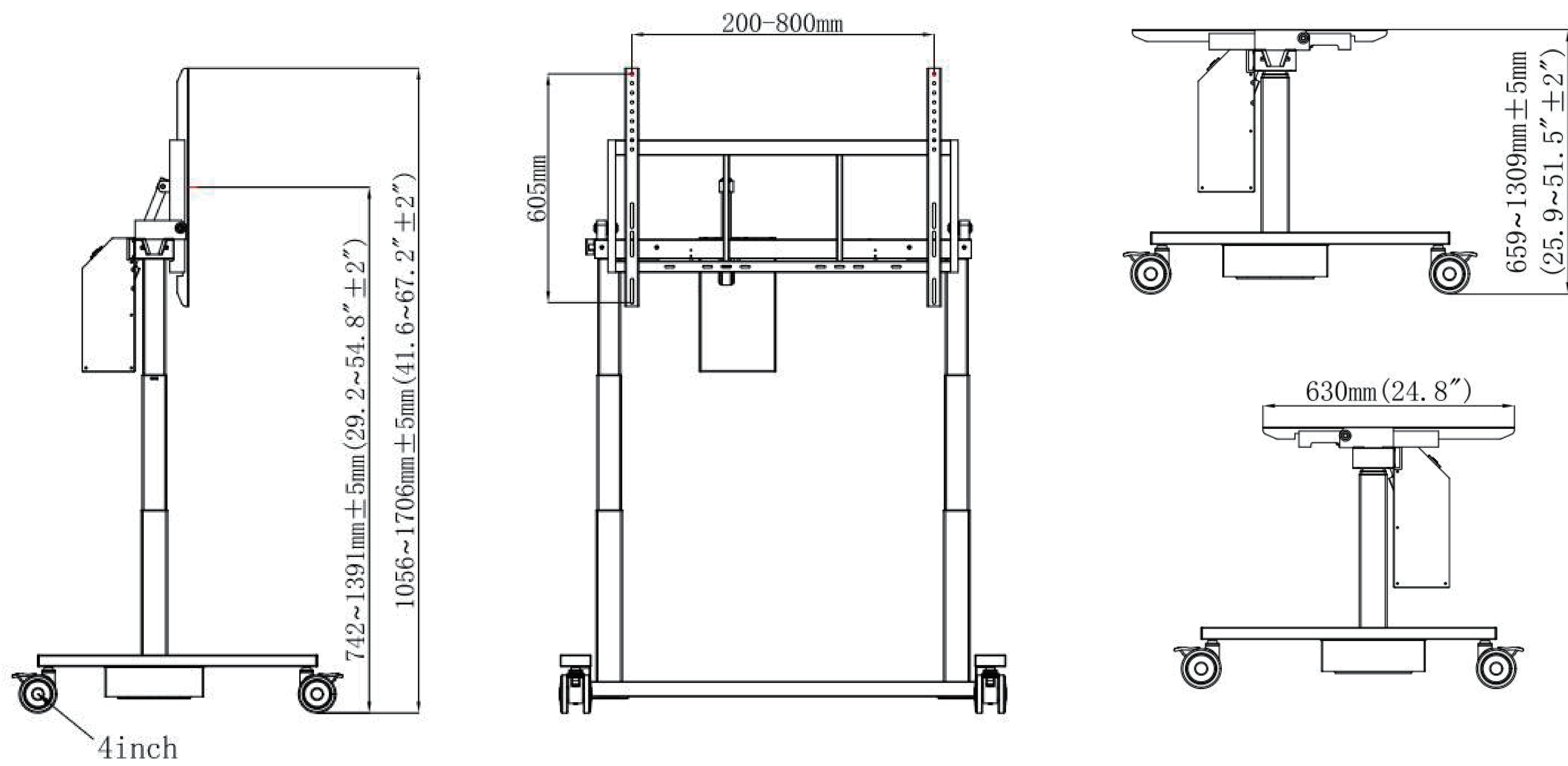

### Physical Specifications

Dimension of the assembled (L*W*H)	1178 × 741 × (1056~1706) mm
Dimension with Package (L×W×H) (L*W*H)	1305 × 825 × 205mm
Power Requirements	100~240V
Lifting Distance	650 mm
Flip Angle	90°±1°
Net Weight	47.3kg
Gross Weight	53.3kg
Largest Bearing	100kg
Max Load Size	Recommending no more than 86 inches
Control Mode	Wired remote controller/ IFP control
Castors	4 Inches Muting Castors
Support Wall-hanging	Standard Dedicated wall mount

### Accessories

AC Power Cable (been installed)	1
USB Adapter Cable	1
Hand Controller	1
Holder For Hand Controller	1
Screw Accessory Package	1
Installation Manual And Instruction For Use	1

### Environmental Conditions

Operation Temperature	0°C - 40°C
Operation Humidity	10% - 90%RH
Storage Temperature	-20°C -60°C
Storage Humidity	10% - 90%RH
Altitude	Below 2000 meters